

Pressure Gauge Isolator Valve, Panel Mounting, Model : 1GIP



the right connection
the right environment

Ref. No : H05427, Release March 2018 (Dimensions in mm)

Description

Seat type Valve for isolating pressure gauges in the systems.
Leakage free construction. No return line needed.
Compact Assembly.
Valve can be mounted on vertical as well as on the horizontal panel face.

Section

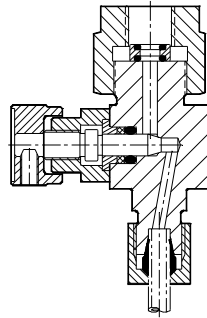

Hydraulic Symbol

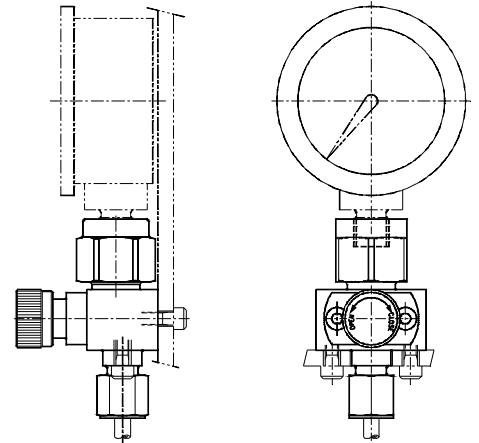

Unit Dimensions

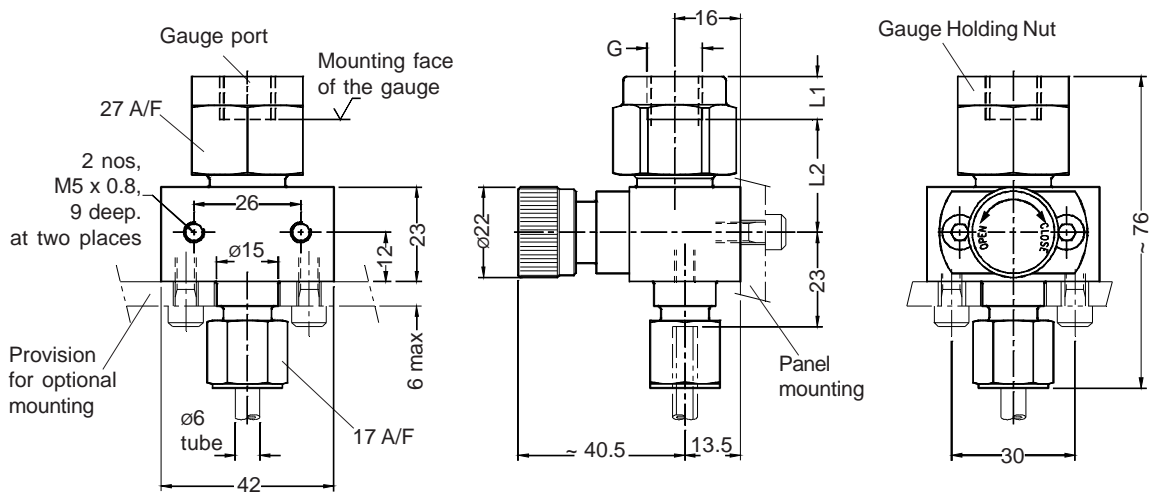

G	G 1/4	G 3/8	G 1/2
L1	10.5	10.0	12.0
L2	27.5	28.5	28.5

Technical Specifications

Construction Seat type.
Mounting Panel mounting.
Mounting position Optional.
Operating pressure 350 bar.
Hydraulic medium Mineral Oil.
Viscosity range 10 cSt to 380 cSt.
Fluid temperature range -20 °C to +70 °C.
Fluid cleanliness As per ISO 19/16 requirement

Instructions for Gauge Assembly

- * Screw in the Gauge Holding Nut onto the valve till its bottom face of it touches the face of the valve body.
- * Insert the sealing ring from the top of the nut.
- * Screw in the gauge into the Gauge Holding Nut till its sealing face touches the sealing ring.
- * Loosen the gauge (if required) by rotating it in anti-clockwise direction till the face of the gauge points towards desired position.
- * Mount the Gauge Isolating Valve on to the panel.
- * Rotate the Gauge Holding Nut by means of a spanner in anti-clockwise direction to tighten the gauge onto the sealing ring. While rotating the nut, hold the gauge to its proper orientation.

Pressure Gauge Isolator Valve, Panel Mounting, Model : 1GIP



the right connection
the right environment

Ref. No : H05427, Release March 2018 (Dimensions in mm)

Ordering Code

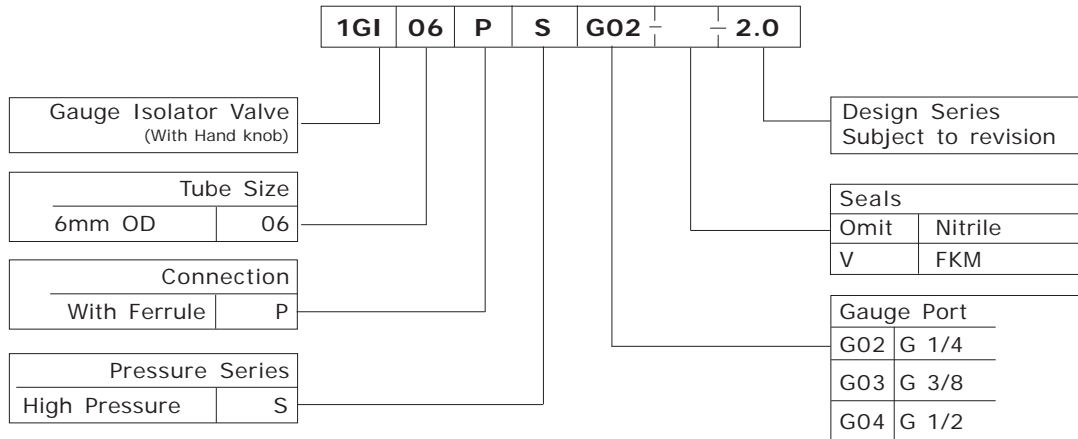

Note : Add prefix 316 to the existing part code for SS 316 valves. e.g. **316-1GI06PSG02-2.0**